



**halliday  
baillie**

## HB 1820

### FLUSH BOLT (ROUND THROW)

The HB 1820 has evolved from HB600 Flush Pull Series. The bolts are milled from solid brass, and incorporate a tension adjusting mechanism in the back for smooth operation. The HB1820 has a HB1825 one metre extension kit available when the bolt is needed away from the top of the door. Also available is the HB1810 which as a flat bar mechanism ideal for aluminium joinery.

Note: please check dimension drawing re suitability with your track requirements

Minimum door thickness: 42mm doors for timber doors.  
35mm for aluminium doors.

Suitable for timber or aluminium doors. Use with the HB 1812 on timber doors.

Available in the following finishes :

(Please check with your H+B representative, not all finishes available in all regions.)

BN : Brushed Nickel	KC : Black Chrome
BSC : Brushed Satin Chrome	PB : Polished Brass
DB : Dark Bronze	PC : Polished Chrome
EBA : Electro™ Black Ace	PN : Polished Nickel
EDB : Electro™ Dark Bronze	SC : Satin Chrome
EMB : Electro™ Medium Bronze	WHT : Appliance White

#### HB 1812 Timber Fixing Kit

2 blocks per kit

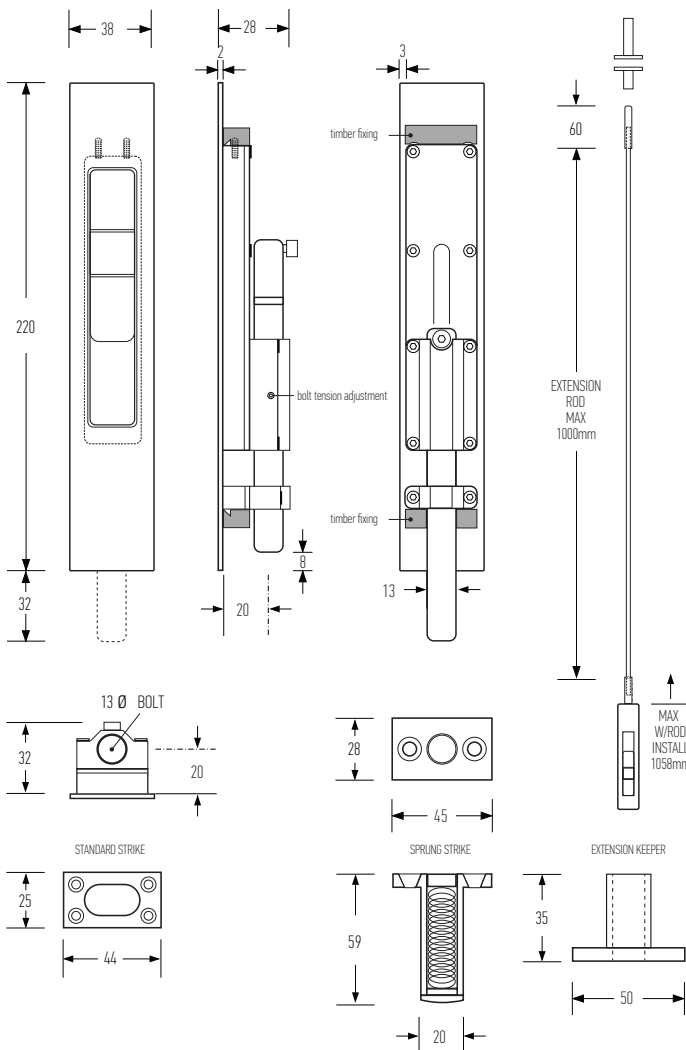
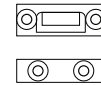

Designed and manufactured in New Zealand. For more information, installation templates, and measured drawings of this product and others please visit : [www.hallidaybaillie.com](http://www.hallidaybaillie.com) or contact your authorized Halliday + Baillie dealer. All information subject to change